

LEKTRO

1190 S.E. Flightline Drive, Warrenton, Oregon 97146-9692
1-800-535-8767 • 503-861-2288 • Fax 503-861-2283
E-mail: sales@lektro.com
http://www.lektro.com

Model AP8600A-M AIRCRAFT TOWING VEHICLE FOR AIRCRAFT UP TO 30,000 LBS/13,608 KG

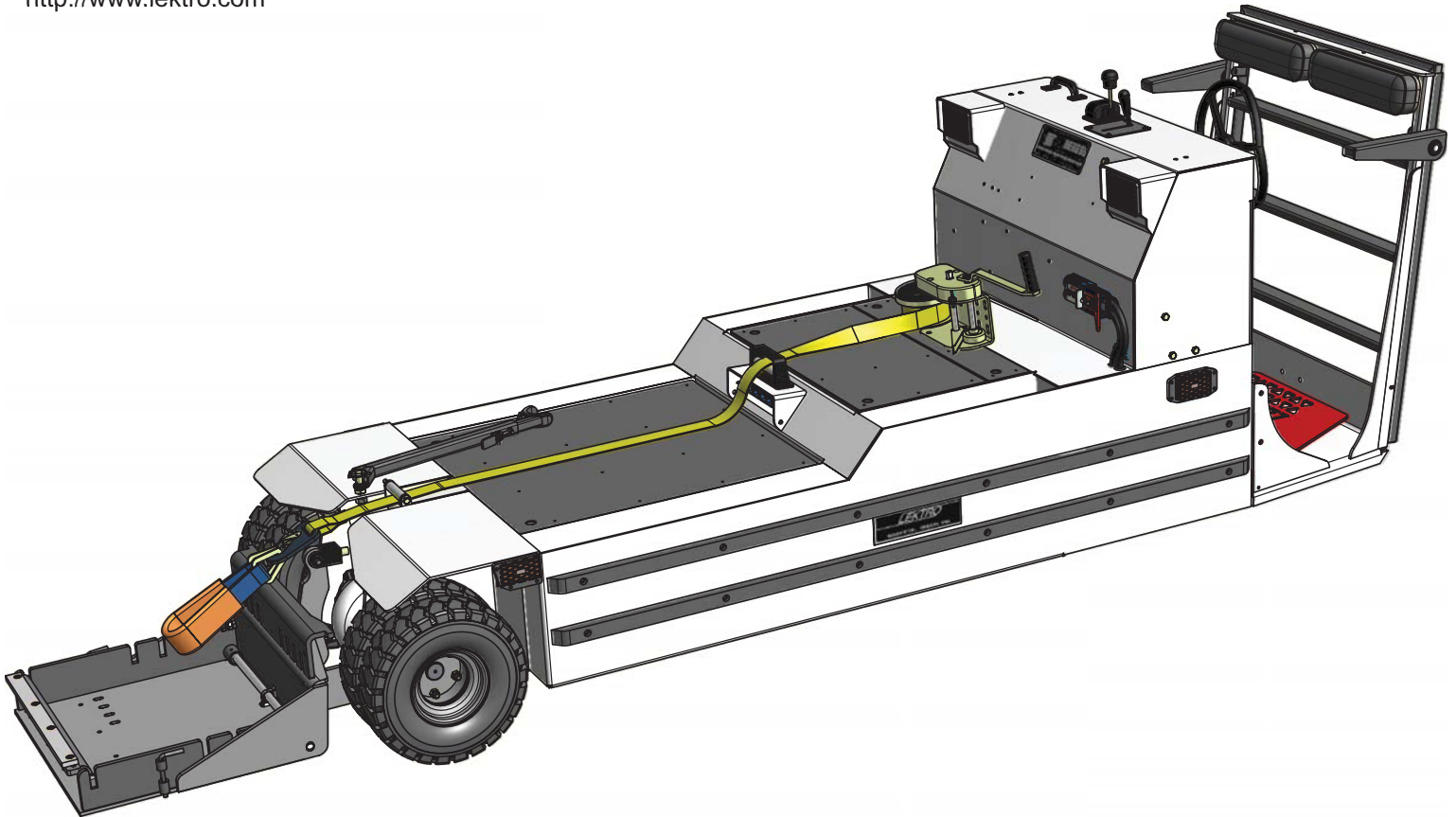

AP8600A-M FEATURES:

Vehicle Drive: 11.8 HP / 8.8 kW motor and 3.73 Limited Slip Differential.

Motor Speed Control: EV-100 LXT Electronic Speed Control with on-board trouble shooting diagnostics. Speed controlled by combination Hand Throttle/Directional Lever.

Batteries: Six 6 VDC, 350 AMP-HR Batteries wired in series with Single Point Watering System.

GPU: Built-in 12/24/28 VDC, 800 CCA Motive / GPU Battery, standard. 1175 CCA system available.

Motive Battery Charger: Fully automatic 36 AMP, 110 VAC, 1-PH Charger, standard. 230 VAC/50 HZ, optional.

Nose Gear Lift Cradle: Lektro's patented Universal Nose Gear Lift Cradle is activated by an Electric/Hydraulic pump assembly and is capable of handling dual and single wheel aircraft as well as those with or without wheel fairings. Steel Extended Rear Gate included.

Winch: Heavy-duty 2-speed Hand Winch. Strut and Winch Straps included.

Steering: Automotive-type wheel coupled to an automotive gear box resulting in very responsive steering action.

Service Brakes: Foot operated single hydraulic disc-type Service Brakes acting at differential pinion shaft.

Parking Brake: Foot operated Automatic Electric Deadman Parking Brake.

Front Drive Tires: Dual 4.80/4.00 x 8 8-ply Poly-foam filled Pneumatic Traction Drive Tires. Chains optional for slippery conditions.

Rear Steer Tires: Dual 4.80/4.00 x 8 6-ply Poly-foam filled Pneumatic Traction Steer Tires. Steer Axle Suspension, optional.

Lighting: Dual Built-in Forward and Aft Headlights, independently activated. One Rear Headlight mounted on back of Operator's Platform. Four Flashing Amber Running Lights identify Sides.

Extension Ladder: Step Ladder attached to operator's back rest.

Operator's Compartment: Two person configuration, stand-up operation with restraint.

Construction: Welded steel plate polymers, protected by primer and industrial, high-gloss red urethane paint. A special protective Polyurethane coating applied to all chassis components to prevent rust, scratches and corrosion, optional. Custom colors are available.

SPECIFICATIONS:

Length.....	151.5 in / 384.6 cm
Width	42.75 in / 108.3 cm
Height (at top of steering wheel).....	49 in / 124.4 cm
Turning Radius	127.5 in / 323.9 cm
Wheel Base	79.75 in / 202.3 cm
Vehicle Speed, Empty	7 MPH / 11.2 KPH
Vehicle Speed, Loaded (To max. Vehicle Capacity) ...	3 MPH / 4.8 KPH
**Lift Cradle Capacity	3000 LBS / 1361 KG
Nose Gear Cradle Lifting Height.....	9 in / 23 cm
Ground Clearance	3.5 in / 9 cm
Chassis Weight w/ Batteries & Charger	2750 LBS / 1247 KG

**Lift Capacity is calculated with 14 in / 36 cm diameter aircraft tire in lift cradle. Aircraft tire centerline at 18.5 in / 47 cm from drive tire centerline.

ADDITIONAL OPTIONS:

Front and Rear Pintle Towing Hooks and Steel Side Rub Rails included. Specialized Aircraft Towing Adapters and Custom Highlift Adapters are available (consult factory). Illustration may show some optional equipment.

*LEKTRO reserves the right to make changes and improvements in products and specifications without notice or obligation.

Patent Nos. 5,151,003/5,302,075. Other Patents Pending. 09/11

LEKTRO

1190 S.E. Flightline Drive, Warrenton, Oregon 97146-9692
1-800-535-8767 • 503-861-2288 • Fax 503-861-2283
E-mail: sales@lektro.com
http://www.lektro.com

Model AP8600A-M AIRCRAFT TOWING VEHICLE FOR AIRCRAFT UP TO 30,000 LBS/13,608 KG

