

LEKTRO

1190 S.E. Flightline Drive, Warrenton, Oregon 97146-9692
1-800-535-8767 • 503-861-2288 • Fax 503-861-2283
E-mail: sales@lektro.com
http://www.lektro.com

Model AP8950SD-M AIRCRAFT TOWING VEHICLE FOR AIRCRAFT UP TO 180,000 LBS/81,648 KG

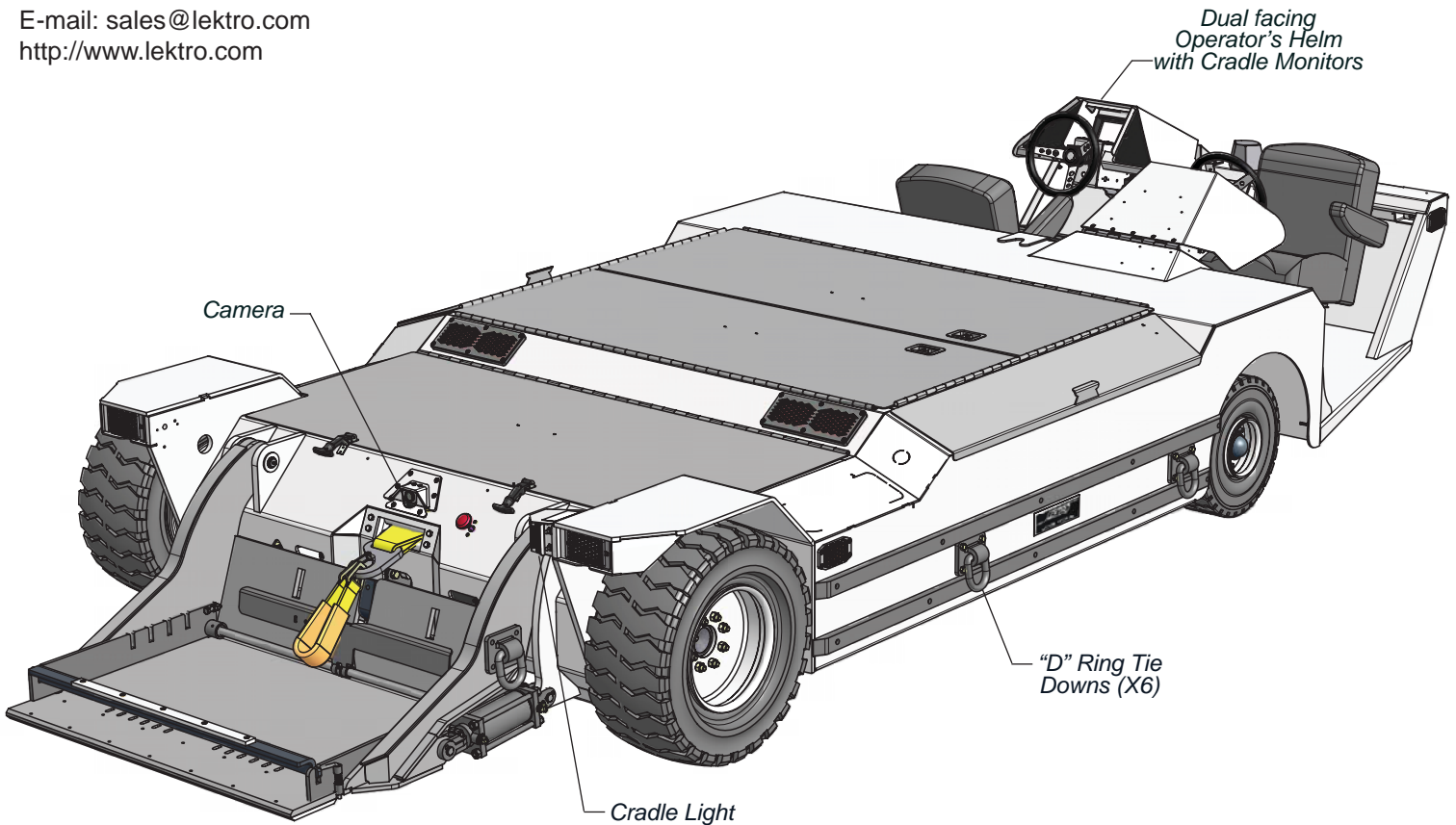

AP8950SD-M FEATURES:

Vehicle Drive: 55.3 HP / 45.5 kW, 80 VDC Traction Motor coupled direct to a heavy-duty Dana 44 Differential.

Motor Speed Control: EV-200 Electronic Speed Control with on-board trouble shooting diagnostics. Speed controlled by Foot Throttle.

Batteries: Dual set of two 40 VDC industrial, 595 AMP-HR Batteries (6 hr rate), wired in series-parallel with Single Point Watering System.

GPU: Built-in 12/24/28 VDC, 1175 CCA output capability with independent batteries and charging system, optional.

Motive Battery Charger: Two fully automatic 100 AMP, 208-480 VAC, 60 HZ, 3-PH Fully Automatic Chargers, standard.

Nose Gear Lift Cradle: Lektro's patented Universal Nose Gear Lift Cradle is activated by an Electric/Hydraulic pump assembly with dual cylinders, and is capable of handling dual and single wheel aircraft as well as those with or without wheel fairings.

Winch: Heavy-duty Hydraulic Winch with automatic safety cut-off. Winch Strap and universal Strut Straps included.

Steering: Electric/Hydraulic Power Steering controlled through automotive type tilt wheel requiring minimal effort with very responsive steering action. Automatic timer shuts down steering motor when tug is not in use, increasing battery shift life.

Service Brakes: Foot operated quad independent hydraulic disc-type Service Brakes utilizing the final wheel drive gearing to achieve maximum braking with minimal brake pedal effort.

Parking Brake: Hand activated, industry standard, "yellow diamond" push/pull electric/hydraulic Parking Brake, coupled to quad auxiliary brake discs on final drive.

Drive Tires: Single 28 x 12.5-15 Semi Pneumatic Traction Drive Tires with Siping. Chains optional for slippery conditions.

Steering Tires: 21 x 8-9 Semi-Pneumatic Traction Steer Tires mounted to a fully suspended steer axle.

Lighting: Dual Forward and dual Aft Headlights, independently activated. Four flashing amber Running Lights positioned around tug to illuminate sides and top. Amber Strobe Light mounted center rear. Front and rear mounted turn signal and brake lights.

Camera and Monitor: Camera at Aircraft Interface Area, and Color Monitors at Operator Instrument Panels, standard.

Seating: Operator and passenger seating with dual facing helms, constructed of industrial grade, weather resistant materials including armrests and seat belt. Operator's seat features a fully suspended, adjustable setting for height, for/aft and weight. Dual facing passenger/operator's helm. Operator's cab with heater, defroster, and windshield wipers, optional.

Construction: Welded steel plate and polymers preserved by primer and automotive high-gloss red or white enamel paint with a special protective Polyurethane coating applied to decks, fenders, side and battery compartments to prevent rust, scratches and corrosion. Custom colors, optional.

Aircraft Towing Vehicle Transport: Steer Axle with hydraulic lift and extended lift cradle for ramp loading, optional. Six "D" Rings and Rear Drawbar Hitch standard for transport tie down.

SPECIFICATIONS:

Length.....	236.8 in / 601.4 cm
Width	100.5 in / 255.4 cm
Height (At lowest steering tilt setting)	37 in / 94 cm
Turning Radius	209 in / 531 cm
Wheel Base	114.7 in / 291.2 cm
Vehicle Speed, Empty	7.5 MPH / 12 KPH
Vehicle Speed, Loaded (To Max. Vehicle Capacity).....	4 MPH / 6.44 KPH
**Lift Cradle Capacity	18,000 LBS / 8165 KG
Nose Gear Cradle Lifting Height.....	11 in / 28 cm
Ground Clearance	5 in / 12.7 cm
Chassis Weight w/o Batteries & Charger	9000 LBS / 4082 KG
Chassis Weight w/ Motive Batteries & Charger.....	18,000 LBS / 8165 KG
Chassis Weight w/ Motive & GPU Batteries & Charger ..	18,350 LBS / 8323 KG

**Lift Capacity is calculated with 30 in / 76.2 cm diameter aircraft tire in lift cradle. Aircraft tire center line at 26 in / 66 cm from drive tire center line.

ADDITIONAL OPTIONS:

Falling Aircraft Protective System. Specialized Aircraft Towing Adapters and Custom Highlift Adapters are available. (consult factory). Illustration may show some optional equipment. *LEKTRO reserves the right to make changes and improvements in products and specifications without notice or obligation.

PATENT Nos. 5,261,778/5,302,075. Other Patents Pending. 09/10

LEKTRO

Model AP8950SD-M AIRCRAFT TOWING VEHICLE FOR AIRCRAFT UP TO 180,000 LBS/81,648 KG

1190 S.E. Flightline Drive, Warrenton, Oregon 97146-9692
1-800-535-8767 • 503-861-2288 • Fax 503-861-2283
E-mail: sales@lektro.com
http://www.lektro.com

